

DOORS 3J

SECTION INDEX

	Page		Page
Cherokee-Wagoneer Rear Doors	3J-12	Power Door Locks	3J-21
Cherokee-Wagoneer-Truck Front Doors	3J-5	Electrically Operated Windows	3J-16
CJ-7 and Scrambler With Hardtop Enclosure	3J-1	Tools	3J-22

CJ-7 AND SCRAMBLER WITH HARDTOP ENCLOSURE

	Page		Page
Door Trim	3J-1	Sealing System	3J-1
Hinge System	3J-5	Window System	3J-2
Lock System	3J-4		

DOOR TRIM

Window Regulator Handle

Window regulator handles are attached to the splined shaft of the window regulator with a 5/32-inch Allen head screw. To remove the handle, remove the screw and pull the handle straight off the shaft.

Install the handle with the knob forward, the handle horizontal and the glass all the way up.

Door Assist Handle

Removal

- (1) Remove screws attaching door assist handle using Torx Bit Tool J-25359-C.
- (2) Remove handle from door.

Installation

- (1) Position handle on door.
- (2) Install attaching screws using Torx Bit Tool J-25359-C.

Trim Panel

Trim panels consist of fiber board composition covered with a vinyl material. They are fastened to the door

with plastic clips inserted into holes in the door inner panel.

Removal

- (1) Remove door assist handle.
- (2) Remove window regulator handle.
- (3) Pry trim panel-to-door clips along sides loose with Trim Pad Depressor Tool J-2631-01 and remove panel.

Installation

- (1) Position trim panel on door and install clips in holes in inner door panel.

NOTE: To prevent creasing the trim panel cover, do not hammer or exert excessive force on the clips.

- (2) Install window regulator handle.
- (3) Install door assist handle.

SEALING SYSTEM

Water Shield

The water shield is attached to the door inner panel with adhesive. To remove water shield, use a putty knife

between shield and door inner panel to break adhesive bond.

When installing water shield, be sure the slit lower portion is tucked inside the door panel at the access opening and that the shield is bonded securely to the door inner panel.

Rubber Sealer

The door rubber sealer is made of molded latex foam with a smooth rubber skin on the outside.

Plastic retainers are used to retain the rubber sealer to the door below the belt line. Barbs on the retainer depress when inserted in the holes and spread when fully inserted. Above the belt line, the sealer is retained in a channel formed in the upper door frame.

Maintenance of Rubber Sealers

Cold weather may cause the rubber sealer to harden and lose resiliency. This may cause the door to loosen in its opening, resulting in noise. When servicing, use a dampened cloth to clean rubber sealer. Remove dirt from all points where the rubber sealer contacts the body. Apply AMC Silicone Lubricant, or equivalent, to sealer.

CAUTION: Do not use graphite, brake fluid, or wax on rubber sealer.

Replacement

Replacement rubber sealers are coated with powder to prevent stickiness in storage. Before installation, remove all powder with cloth dampened in 3M General Purpose Adhesive Cleaner, or equivalent.

(1) Carefully remove rubber sealer from door using Weatherstrip Remover J-21104-01 to remove plastic retainers from panel holes. Remove upper portion from upper door frame with fingers or wooden wand.

(2) Remove dust and dirt from rubber sealer, door and body.

(3) Install upper front corner of sealer to door first using fingers or wooden wand to engage sealer into channel. Place inner shoulder of sealer in channel-to-window frame above belt line.

(4) Press retainers, starting at rear edge of door, into door panel holes.

WINDOW SYSTEM

Door Glass

Adjustment

One adjustment point is available which regulates the amount of effort required to raise and lower the door glass. The door glass division channel is adjustable fore and aft at the lower attachment point.

(1) Remove door trim panel and water shield.

(2) Loosen division channel lower adjusting screw and move division channel fore or aft to obtain desired door glass operation (fig. 3J-1).

NOTE: Movement of division channel fore and aft reduces or increases free play between channels.

(3) Tighten division channel lower adjusting screw.
(4) Install water shield and door trim panel.

Removal

(1) Remove door trim panel and water shield.

(2) Remove glass down-stop.

(3) Remove screws attaching guide channel to plastic fasteners. Remove guide channel and plastic fasteners.

(4) Lower glass to bottom of door.

(5) Remove division channel upper attaching screw and lower adjusting screw. Disengage front three inches of glass weatherstrip from upper door frame.

(6) Separate division channel from front glass rubber. Pull division channel up and in toward inside of vehicle.

(7) Raise and tilt glass toward hinge side of door and disengage from rear channel.

(8) Pull glass up and out of door panel.

Installation

(1) Lower glass into door, while positioning glass into front and rear channels.

(2) Install plastic fasteners into glass.

(3) Slide glass down into bottom of door panel.

(4) Lower division channel into door and position glass securely in channel.

(5) Engage weatherstrip in upper door frame and install upper attaching screw and lower adjusting screw.

(6) Slide guide channel onto regulator arm and position channel on glass. Install attaching screws.

(7) Install glass down-stop.

(8) Check operation and adjustment.

(9) Install water shield and door trim panel.

Stationary Vent Window

Removal

(1) Remove door trim panel and water shield.

(2) Lower glass to down-stop.

(3) Remove division channel upper attaching screw and lower adjusting screw.

(4) Disengage front three inches of weatherstrip from upper door frame. Lower division channel and tilt toward rear of door.

(5) Remove stationary vent glass from weatherseal.

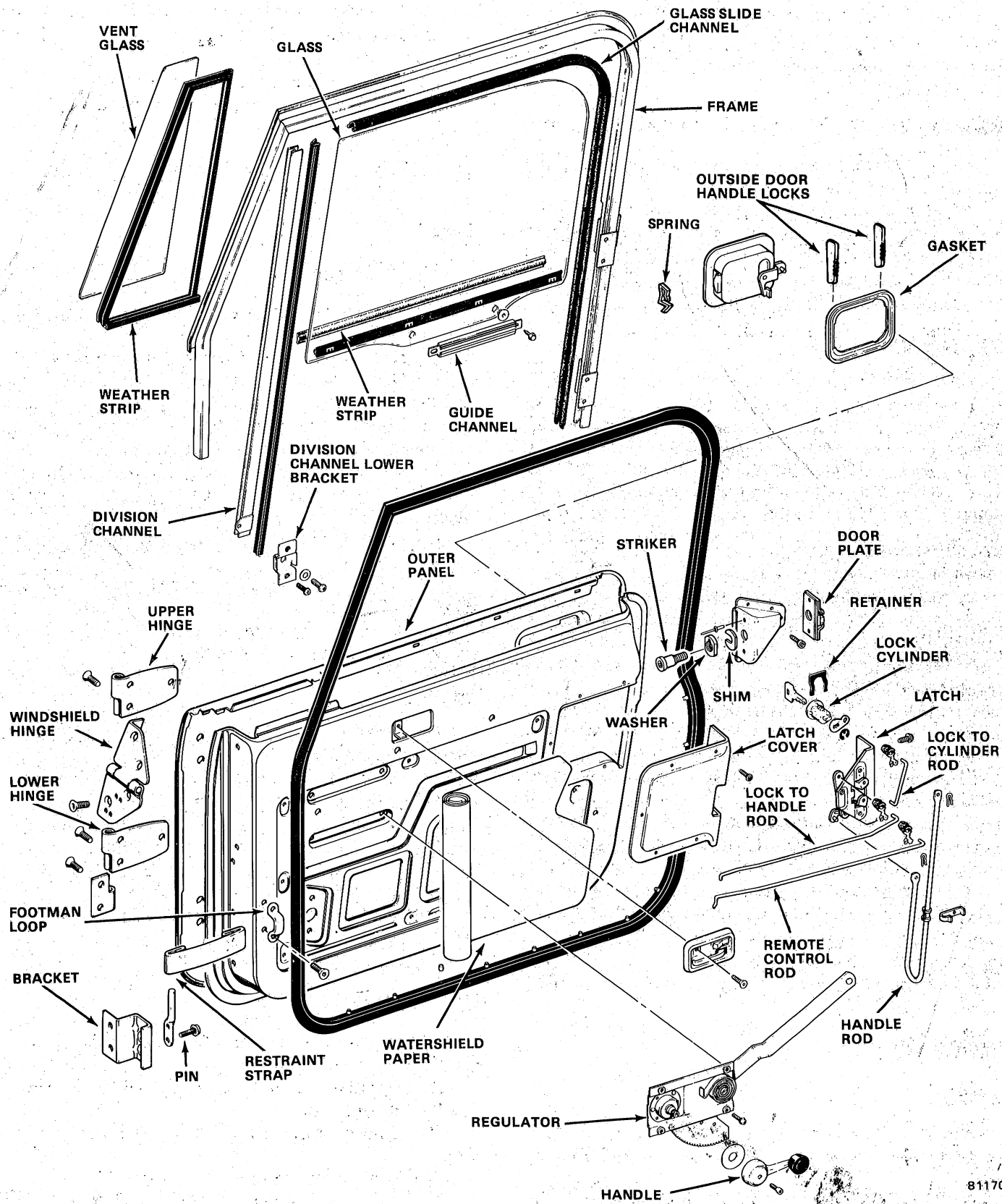

81170

Fig. 3J-1 Front Door Exploded View—CJ and Scrambler Models

Installation

- (1) Install stationary vent glass into weatherseal.

NOTE: *It is necessary to seat front edge of weatherstrip into door frame. Then, seat vent glass into weatherstrip.*

- (2) Install division channel into door and position channel on glass.
- (3) Install upper attaching screw and lower adjusting screw.
- (4) Engage weatherstrip in upper door frame.
- (5) Water test and check for leaks.
- (6) If water leakage is evident, apply 3M Windshield Sealer, or equivalent, or realign weatherseal.
- (7) Check operation and adjustment of door glass.
- (8) Install water shield and door trim panel.

Window Regulator**Removal**

- (1) Remove trim panel and water shield.
- (2) Lower glass to expose guide channel fasteners. Remove fasteners and guide channel. Raise window to full up position and apply masking tape to glass and over top of window frame.
- (3) Remove division channel lower adjusting screw.
- (4) Remove regulator attaching screws. Push division channel outward and remove regulator through access hole in inner door panel.

Installation

- (1) Position regulator in door and install attaching screws.
- (2) Remove masking tape from glass and lower glass.
- (3) Slide guide channel onto regulator arm and position channel on glass. Install attaching screws.
- (4) Install division channel lower adjusting screw.
- (5) Check operation.
- (6) Install water shield and door trim panel.

LOCK SYSTEM**Door Lock Cylinder****Removal**

- (1) Remove door trim panel and watershield paper.
- (2) Remove door latch cover screws and remove cover.
- (3) Remove retaining clip and remove lock-to-cylinder rod.
- (4) Remove lock cylinder spring retainer and remove lock cylinder and gasket.

Installation

- (1) Install gasket and lock cylinder in door.
- (2) Install lock cylinder spring retainer and install lock to cylinder rod and clip.
- (3) Install door latch cover and cover screws.
- (4) Install watershield paper and door trim panel.

Outside Handle Replacement**Removal**

- (1) Remove door handle assist and window regulator handle.
- (2) Remove door trim panel and watershield paper from door.
- (3) Remove door latch cover attaching screws.
- (4) Disconnect lock-to-handle rod from outside door handle.
- (5) Close window completely, pry lock spring to outside and tap handle locks upward (fig. 3J-1).
- (6) Disconnect window door glass from regulator.
- (7) Remove division channel upper and lower attaching screws.
- (8) Separate division channel from front glass rubber.
- (9) Pull division channel upward and remove window glass from door.
- (10) Remove locks from outer door handle using needle-nose pliers and remove handle from door.

Installation

- (1) Install outside door handle and slide locks into door handle from top.
- (2) Tap locks downward lightly to tighten handle.
- (3) Install lock-to-handle rod and lock pin.
- (4) Position window glass in door and channels.
- (5) Install division channel and attaching screws.
- (6) Attach window glass to regulator.
- (7) Install door latch cover.
- (8) Install watershield paper and door trim panel.
- (9) Install window regulator handle.
- (10) Install door handle assist.

Latch Replacement

- (1) Remove door trim panel and watershield paper.
- (2) Remove latch cover.
- (3) Disconnect remote control rod and lock-to-handle rod from latch.
- (4) Remove latch attaching screws and remove latch.
- (5) Install latch and attaching screws.
- (6) Connect remote control rod and lock-to-handle rod from latch.
- (7) Install latch cover and tighten cover screws.
- (8) Install watershield paper and door trim panel.

HINGE SYSTEM

Adjustments

The doors are adjusted at the hinge mounting points on the body or door.

Enlarged holes are provided in the body, lower hinge only, for fore, aft and tilt adjustments. Enlarged holes are also provided in the door, upper and lower hinges, for up, down, fore, aft and tilt adjustments.

Prior to any door adjustment or alignment, the door latch must be removed to allow the door to close freely in proper alignment.

The door latch striker should be adjusted in or out to allow the door latch to be fully engaged. The door should be flush with the adjacent body panels.

Replacement

(1) Mark outline of existing hinge on body and door with wax pencil.

NOTE: When removing door or hinge DO NOT lose the plastic shims on the hinge pin.

(2) Remove hinge-to-body screws and hinge-to-door screws using Torx Bit Tool J-25359-C and remove hinge.

NOTE: Upper hinge is part of windshield hinge assembly. When replacing, adequately support the windshield frame prior to removal and check alignment after installation.

(3) Clean replacement hinge in suitable solvent and blow dry with compressed air.

(4) Color-coat hinge to match body using Jeep exterior spray paint, or equivalent.

(5) Lubricate hinge with 3M 4-Way Spray lubricant, or equivalent.

(6) Position hinge on door, align carefully with wax pencil marks, and install screws using Torx Bit Tool J-25359-C.

(7) Position hinge on body, align carefully with pencil marks, and install screws using Torx Bit Tool J-25359-C.

(8) Check door alignment. Adjust if necessary. Refer to Door Adjustment.

CHEROKEE - WAGONEER - TRUCK FRONT DOORS

	Page		Page
Door Trim	3J-5	Outside Mirrors	3J-10
Hinge System	3J-9	Sealing System	3J-6
Lock System	3J-8	Window System	3J-6

DOOR TRIM

Window Regulator Handle

Window regulator handles are attached to the splined shaft of the window regulator with a 5/32-inch Allen head screw. To remove the handle, remove the screw and pull the handle straight off the shaft.

Install the handle with the knob forward, the handle horizontal and the glass all the way up.

Trim Panel

Trim panels consist of fiber board composition covered with a vinyl material. They are fastened to the door with plastic clips inserted into holes in the door inner panel and screws along the bottom edge.

Removal

(1) Remove overlay on armrest, if equipped, and remove attaching screws and armrest.

(2) Remove window regulator handle, if equipped, and door latch remote control handle.

(3) Remove assist handle, if equipped.

(a) Remove woodgrain insert at both ends of assist handle.

(b) Remove attaching screws and assist handle.

(4) Remove power door lock/window bezel, if equipped.

(5) Remove trim panel attaching screws on bottom of trim panel.

(6) Pry trim panel-to-door clips along sides loose with tool J-2631-01 and remove panel.

(7) Loosen setscrew securing remote control mirror control cable to escutcheon, if equipped, and remove trim panel.

Installation

(1) Insert remote control mirror control cable in escutcheon and tighten setscrew, if equipped.

(2) Position trim panel on door and install clips in holes in inner door panel.

NOTE: To prevent creasing the trim panel cover, do not hammer or exert excessive force on the clips.

- (3) Install screws along bottom of trim panel.
- (4) Install window regulator handle, if equipped, and door latch remote control handle.
- (5) Install armrest and overlay.
- (6) Install assist handle, if equipped.
 - (a) Position assist handle and install attaching screws.
 - (b) Install woodgrain inserts.
- (7) Install power door lock/window bezel, if equipped.

Replacement

- (1) Remove door trim panel.
- (2) If equipped with door mounted speaker, proceed as follows:
 - (a) Remove speaker grille and bezel from original panel.
 - (b) Cut speaker grille opening in replacement panel, following outline provided on backside of panel, with sharp knife.
 - (c) Install speaker grille and bezel on replacement panel.
- (3) If equipped with manual window regulator or remote mirror, cut opening(s) in replacement trim panel, following outline provided on backside of panel, with sharp knife.
- (4) If equipped with power window or power door locks, cut opening(s) in replacement trim panel following outline provided on backside of panel with sharp knife.
- (5) Transfer door trim panel attaching clips to replacement panel.
- (6) Install door trim panel.

SEALING SYSTEM

Water Shield

The water shield is attached to the door inner panel with adhesive. To remove water shield, use a putty knife between shield and door inner panel to break adhesive bond.

When installing water shield be sure the tab on the lower portion is tucked inside the door panel slit at the access opening and that the shield is bonded securely to the door inner panel.

Rubber Sealer

The door rubber sealer is made of molded latex foam with a smooth rubber skin on the outside.

The door rubber sealer is attached to the body opening around the door opening.

Maintenance of Rubber Sealers

Cold weather may cause the rubber sealer to harden and lose resiliency. When servicing, use a dampened cloth to clean rubber sealer. Remove dirt from all points where the rubber sealer contacts the door. Apply AMC/Jeep Silicone Lubricant, or equivalent, to a dampened cloth and apply to rubber sealer.

CAUTION: Do not use graphite, brake fluid, or wax on rubber sealer.

Replacement

Replacement rubber sealers are coated with powder to prevent stickiness in storage. Before installation, remove all powder with a cloth dampened with 3M General Purpose Adhesive Cleaner, or equivalent.

- (1) Carefully remove rubber sealer from door opening.
- (2) Remove dust and dirt from rubber sealer, door and body opening.
- (3) Install upper front corner of sealer to body first.
- (4) Work rubber sealer onto flange completely around door opening.

WINDOW SYSTEM

Door Glass

Removal

- (1) Remove door trim panel and water shield.
- (2) Remove glass stop bracket (fig. 3J-2).
- (3) Remove lower division channel attaching bracket.
- (4) Remove division channel upper bracket-to-door panel attaching screws.
- (5) Remove lock rod guide bushing and push knob.

NOTE: Move lock rod aside so glass may be lowered to bottom of door.

- (6) Remove screws attaching remote control assembly to door panel and lower to bottom of door.
- (7) Lower door glass and remove retaining clip.
- (8) Lower glass to bottom of door.
- (9) Push lower end of division channel toward front of door to release glass from channel.
- (10) Move glass toward front of door to release it from rear channel.
- (11) Rotate glass vertically 90° and guide it between inner and outer door panels.

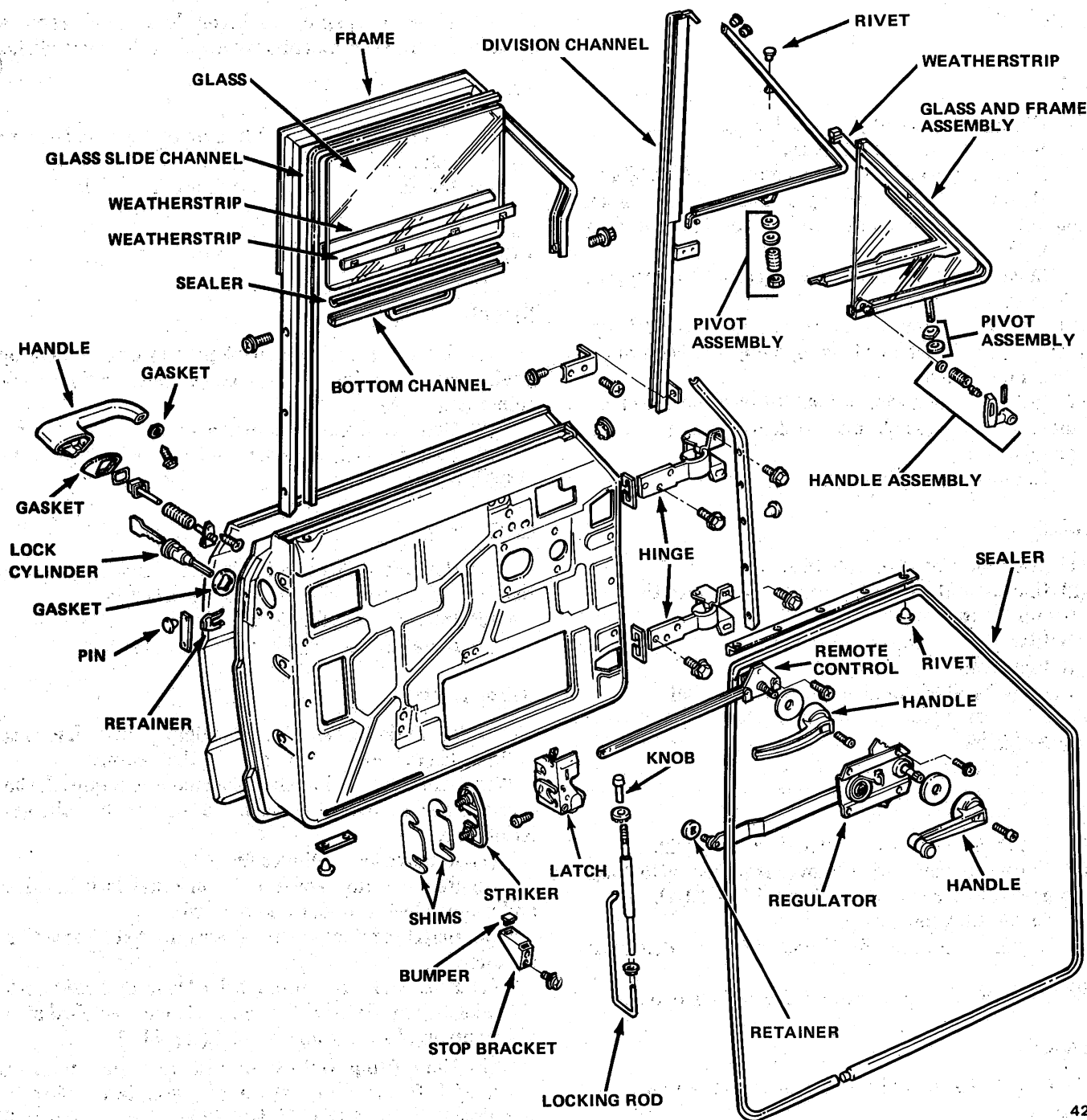

42654

Fig. 3J-2 Front Door—Cherokee-Wagoneer-Truck Models

Installation

- (1) Position door glass in lower section of door so bottom channel has recessed portion of guide groove toward outer door panel.
- (2) Position glass in rear channel and position front channel so glass can be inserted.
- (3) Slide glass up channels and crank regulator arm down to align pin at end of regulator arm with slot in bottom channel.
- (4) Install retainer on regulator arm.
- (5) Position remote control assembly and install attaching screws.
- (6) Position lock rod and install lock rod guide bushing to door panel.
- (7) Install door lock push knob.
- (8) Install upper and lower division bar attaching brackets.
- (9) Install glass stop bracket.
- (10) Check glass operation and adjustment.
- (11) Install water shield and trim panel.

Vent Window**Removal**

- (1) Remove door trim panel and water shield.
- (2) Remove door window glass.
- (3) Remove glass slide channel along top (fig. 3J-2).
- (4) Remove vent assembly attaching screws on leading edge of door frame and under base of vent weatherseal.
- (5) Move vent assembly toward rear of door, tipping it to clear upper door frame.
- (6) Pull ventilator assembly straight out until upper attaching bracket is above opening between outer and inner door panels.
- (7) Rotate vent assembly 90° to position lower attaching bracket on run channel to clear opening between door panels.
- (8) Remove vent assembly.

Installation

- (1) Position vent assembly in door.
- (2) Install vent assembly attaching screws through door frame.
- (3) Install upper glass slide channel.
- (4) Install door window glass.
- (5) Install water shield and door trim panel.

Window Regulator**Removal**

- (1) Remove door trim panel and water shield.
- (2) Lower glass and remove retainer attaching regulator arm to glass bottom channel (fig. 3J-2).
- (3) Raise and support glass.
- (4) Lower regulator arm and remove attaching screws.
- (5) Remove regulator through access hole in door.

Installation

- (1) Install regulator in door and secure with attaching screws.
- (2) Position regulator arm in glass bottom channel.
- (3) Install retainer on regulator arm.
- (4) Remove glass support.
- (5) Install water shield and door trim panel.

LOCK SYSTEM**Outside Handle****Removal**

- (1) Remove door trim panel and water shield.
- (2) Raise window to fully closed position.

- (3) Through opening in inner door panel, remove handle attaching screws and remove handle and gaskets.

Installation

- (1) Position gaskets and handle on door and secure with attaching screws.
- (2) Install water shield and door trim panel.

Key Lock**Removal**

- (1) Remove rubber sealer along rear edge of door by prying out retaining pins to expose lock cylinder retainer (fig. 3J-2).
- (2) Using flat-bladed screwdriver, remove retainer.
- (3) Remove lock cylinder and extension rod from outside of door.

Installation

- (1) Position lock cylinder in door, making sure extension rod is inserted in square hole in latch.
- (2) Install lock cylinder retainer.
- (3) Install rubber sealer with retaining pins.

Lock Cylinder Coding

A lock cylinder service kit is available which includes an uncoded cylinder, housing and a dust cover.

Whenever a lock cylinder replacement is required, the uncoded service cylinder can be coded to match the existing key.

- (1) Remove lock cylinder from door.
- (2) Remove dust cover from original lock housing and remove lock cylinder and discard.
- (3) Insert original key into new uncoded service lock cylinder.

(4) Press cylinder into special Door Cylinder Lock Tumbler Filing Fixture, Tool J-22977, with notched side of key up and long tumbler in slot (fig. 3J-3).

(5) Hold filing fixture in vise and file tumblers flush with flat side of fixture. Use standard 5/8-inch, double-cut bastard file. Finish filing with smooth mill file.

(6) Remove lock cylinder from fixture and insert cylinder into opposite end of fixture with notched side of key down (fig. 3J-3).

NOTE: *This side of the fixture can be identified as the end without the double slot cut out (180° apart).*

- (7) File tumblers flush with flat side of fixture.

NOTE: *Utilize the filing fixtures as a test gauge. Remove the fixture from the vise and if the tumblers are filed correctly, the lock cylinder will turn in the fixture.*

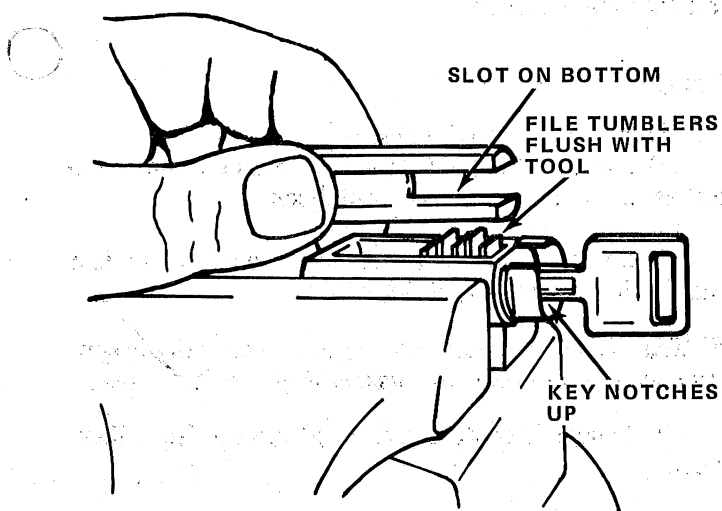

STEP 1

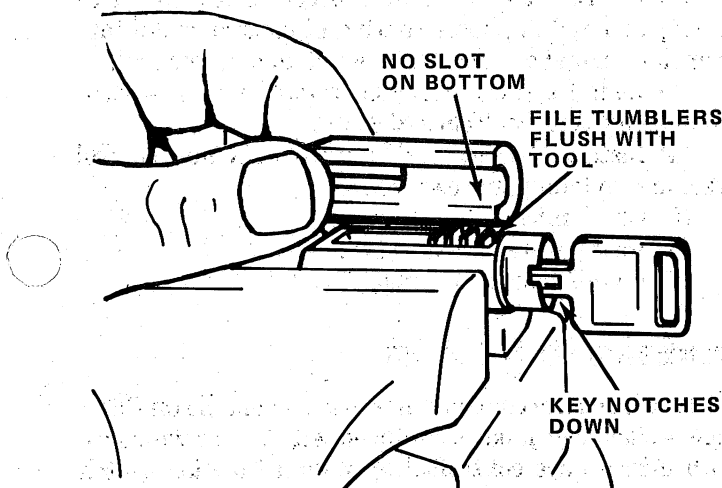

STEP 2

42655

Fig. 3J-3 Filing Lock Tumblers

- (8) Insert new lock cylinder into lock housing.
- (9) Install new dust cap and crimp ends of cap over lock housing.
- (10) Install lock cylinder in door.

Latch and Remote Control

Removal

- (1) Remove door trim panel and water shield.
- (2) Remove lock cylinder.
- (3) Remove screws from door lock remote control (fig. 3J-2). Push control in and lower to bottom of door.
- (4) Disconnect remote control arm from door latch and remove remote control assembly through access hole at bottom of door.
- (5) Remove screws attaching door latch to door panel using Torx Bit Tool J-25359-C.

- (6) Push door latch in and turn it 90° to free it from lock lever rod and remove through lower access hole.

Installation

- (1) Connect lock lever rod to door latch.
- (2) Position door latch on door panel and install attaching screws using Torx Bit Tool J-25359-C.
- (3) Connect remote control arm to door latch. Position remote control on door inner panel and install attaching screws.
- (4) Install outside lock assembly.
- (5) Install water shield and door trim panel.

Locking Rod

Removal

- (1) Remove door trim panel and water shield.
- (2) Remove door lock push knob.
- (3) Push nylon bushing (on rod) off bracket.
- (4) Loosen latch mounting screws using Torx Bit Tool J-25359-C and disengage locking rod.

Installation

- (1) Engage locking rod to latch and tighten latch mounting screws using Torx Bit Tool J-25359-C.
- (2) Install nylon bushing on bracket.
- (3) Install door lock push knob.
- (4) Install water shield and door trim panel.

HINGE SYSTEM

Replacement

- (1) Remove trim panel and water shield.
- (2) Disconnect electrical harnesses inside door and remove harnesses.
- (3) Mark outline of existing hinges on body pillar and door for reference with wax pencil.
- (4) Position door in holding fixture.
- (5) Remove all hinge-to-body screws.
- (6) Remove door from vehicle.
- (7) Remove all hinge-to-door screws and remove hinges.
- (8) Clean replacement hinges in suitable solvent and blow dry with compressed air.

CAUTION: Do not immerse hinge in solvent.

- (9) Color coat hinges to match body.
- (10) Lubricate hinges with 3M 4-Way Spray lubricant, or equivalent.
- (11) Position hinges on door, being careful to align with scribe marks and install attaching screws. Tighten screws to 25 to 35 foot-pounds (34 to 47 N•m) torque.
- (12) Position door in body opening and align hinges with scribe marks on body pillar. Install and tighten two

outside screws, then install and tighten inner screw on each hinge. Tighten screws to 25 to 35 foot-pounds (34 to 47 N•m) torque.

- (13) Remove door holding fixture.
- (14) Position electrical harnesses inside door.
- (15) Check door alignment. Adjust if necessary (refer to Door Adjustment).
- (16) Connect electrical harnesses.
- (17) Install water shield and trim panel.

Door Adjustments

The doors are adjusted at the hinge mounting points on the body or door.

The slotted center hole is provided in the hinge for in or out adjustment on the pillars. The upper and lower holes in the hinge set the door outboard slightly. To adjust the door inboard, loosen the center screw and push the door open against door stop. Tighten the center screw after correct alignment has been achieved.

To adjust up or down or fore and aft, loosen the hinge attaching screws in the door and move the door to the desired position and tighten the screws.

Prior to any door adjustment or alignment, the adjustable striker must be removed to allow the door to close freely in proper alignment without striker interference.

The door lock striker is adjustable up, down, in or out and can be shimmed forward or back to hold the door in the properly aligned position.

The door latch striker should be set so that the latch enters the striker without binding, yet provides secure retention for the lock and prevents up and down or in and out movement of the door.

The striker should also be adjusted in or out to allow the door latch to be fully engaged. The door should be flush with the adjacent body panels.

NOTE: *It is possible to set the striker in so far that the door is closed tight but only the safety catch is engaged. This prevents locking the door with the pushbutton lock rod.*

OUTSIDE MIRRORS

Standard Mirror

Removal

- (1) Remove screws attaching mirror to door panel.
- (2) Remove mirror and gasket from door panel.

Installation

- (1) Position gasket and mirror on door panel.
- (2) Install screws attaching mirror to door panel.

Remote Control Mirrors

Removal

- (1) Remove door trim panel.
- (2) Remove setscrew attaching mirror remote control assembly to trim panel escutcheon.
- (3) Remove water shield paper.
- (4) Remove screws attaching remote mirror-to-door panel using Torx Bit Tool J-25359-C.

NOTE: *Check and note routing of remote mirror control cables before removing assembly from door panel.*

- (5) Remove remote mirror and gasket from door panel.

Installation

- (1) Assemble remote mirror and gasket.
- (2) Insert remote mirror control cables into door outer panel and duplicate routing of control cables into door inner panel as previously noted during removal.
- (3) Install screws attaching remote mirror-to-door panel using Torx Bit Tool J-25359-C.
- (4) Install setscrew attaching mirror remote control assembly to trim panel escutcheon.
- (5) Check mirror operation.
- (6) Install water shield paper.
- (7) Install door trim panels.

Electric Remote Control Mirrors

Electric remote control mirrors are available on Cherokee—Wagoneer models equipped with power windows. Both mirrors are controlled by a dual function switch located on the left front door panel. The left/right control switch is used for directing current to the desired mirror. The horizontal/vertical switch directs current to the motor in the mirror assembly which moves the mirror as desired. A safety or overrun feature is designed into the mirror to prevent damage to the motor when the mirror is moved by hand or when running the mirror to the maximum limit. When the mirror is moved by hand or run to the maximum limit, a distinct snapping noise can be heard.

Electric Motor/Switch Test

Before conducting the electric motor/switch test, be sure the battery is fully charged and all connections are clean and tight.

- (1) Check accessory fuse.
- (2) Check for good ground wire (black) connection located at base of fuse panel.
- (3) Remove door trim panel.
- (4) Using test light, check for current as follows:
 - (a) Orange input wire to switch—if no current is present, check for broken ground (black) wire or feed

(orange) wire between switch and fuse panel. If orange wire checks good, check switch output next (fig. 3J-4).

(b) Check for current at horizontal (yellow) wire and vertical (white) wire. If current is not found in both yellow and white wire, replace switch. If current is found in both yellow and white wire, replace the mirror.

NOTE: When checking the yellow and white wire the control switches must be activated before checking for current.

NOTE: Before replacing the right side mirror, check for current input at the motor.

Switch Removal

- (1) Remove door trim panel.
- (2) Loosen setscrew on mirror switch escutcheon and remove switch from trim panel.
- (3) Remove water dam paper.
- (4) Disconnect wiring harness from mirror and door harness.
- (5) Remove switch.

Switch Installation

- (1) Plug switch connectors into wiring harness from mirror and body.
- (2) Position switch in door panel.
- (3) Install water dam paper.

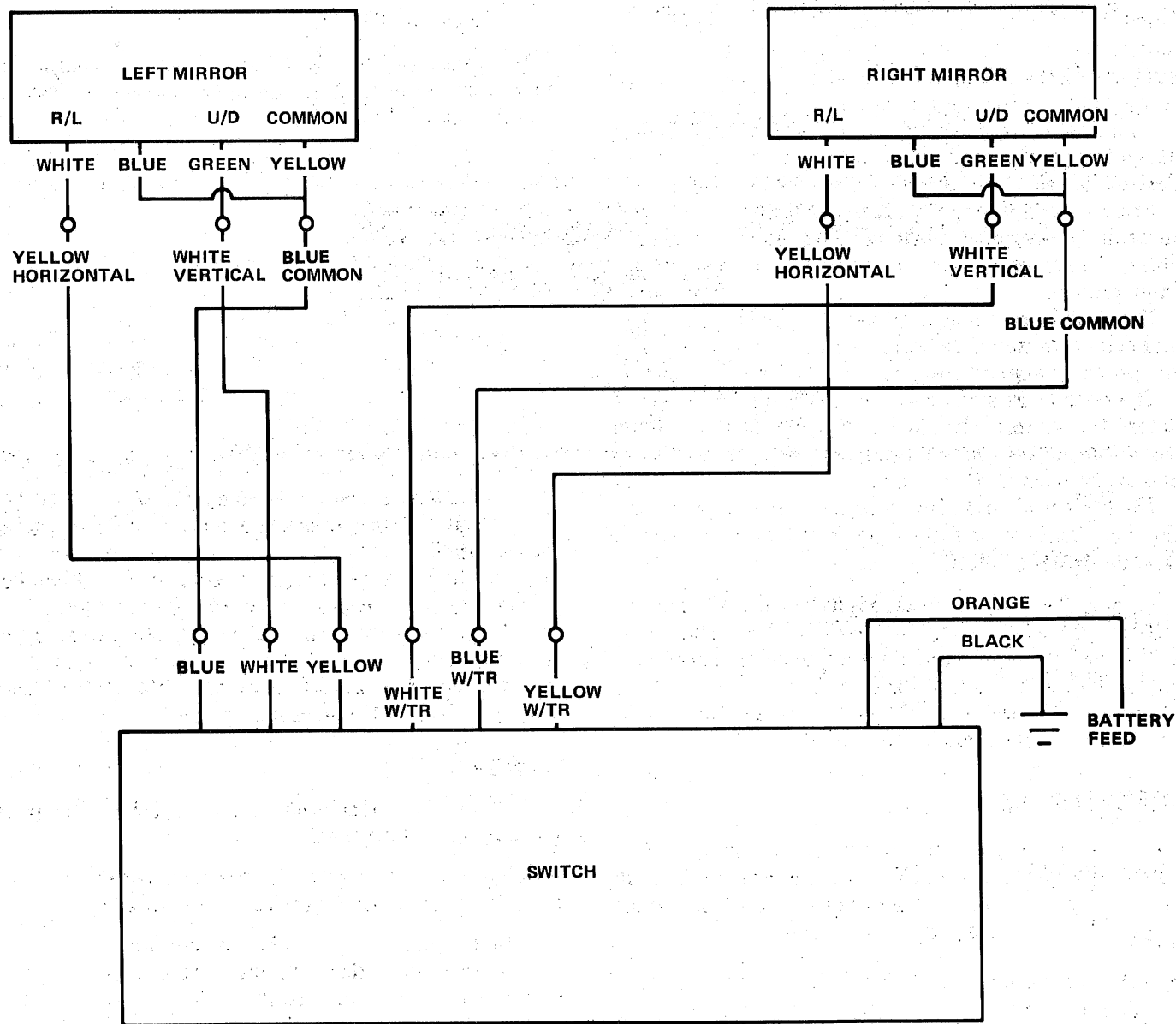

Fig. 3J-4 Electric Mirror Circuit Diagram

- (4) Position switch housing in hole in trim panel, and tighten setscrew.
- (5) Install trim panel.

Mirror Removal—Left Door

- (1) Remove door trim panel.
- (2) Loosen setscrew on mirror switch escutcheon and remove switch from trim panel.
- (3) Remove water dam paper.
- (4) Disconnect door wiring harness from mirror harness.
- (5) Remove tape holding mirror harness to inner door panel.
- (6) Remove mirror retaining screws using Torx Bit Tool J-25359-C. Remove mirror and gasket from outer door panel. Pull mirror harness out of door and gasket.

Mirror Installation—Left Door

- (1) Feed mirror harness through hole in gasket and

- then through door panel and install retaining screws using Torx Bit Tool J-25359-C.
- (2) Tape mirror harness to inner door panel.
- (3) Connect body wiring harness to mirror harness.
- (4) Install water dam paper.
- (5) Install switch in trim panel and tighten setscrew.
- (6) Install door trim panel.

Mirror Removal—Right Door

Removal of the right door mirror is accomplished in the same manner as the left door mirror with the exception of removing the mirror switch. There is no switch on the right door.

Mirror Installation—Right Door

Installation of the right door mirror is accomplished in the same manner as the left door mirror less the installation of the switch.

CHEROKEE - WAGONEER REAR DOORS

	Page		Page
Door Trim	3J-12	Sealing System	3J-13
Hinge System	3J-15	Window System	3J-13
Lock System	3J-15		

DOOR TRIM

Window Regulator Handle

Window Regulator handles are attached to the splined shaft of the window regulator with a 5/32-inch Allen head screw. To remove the handle, remove the screw and pull the handle straight off the shaft.

Install the handle with the knob forward, the handle horizontal and the glass all the way up.

Trim Panel

Trim panels consist of fiber board composition covered with a vinyl material. They are fastened to the door with spring clips inserted into holes in the door inner panel and screws along the bottom edge.

Removal

- (1) Remove overlay on armrest, if equipped, and remove attaching screws and armrest.
- (2) Remove window regulator handle, if equipped, and door latch remote control handle.

- (3) Remove assist handle, if equipped.
 - (a) Remove woodgrain inserts at both ends of assist handle.
 - (b) Remove attaching screws and assist handle.
- (4) Remove power window bezel, if equipped.
- (5) Remove trim panel attaching screws on bottom of trim panel.
- (6) Pry trim panel-to-door clips along sides loose with Tool J-2631-01 and remove panel.

Installation

- (1) Position trim panel on door and install clips in holes in inner door panel.

NOTE: To prevent creasing the trim panel cover, do not hammer or exert excessive force on the clips.

- (2) Install screws along bottom of trim panel.
- (3) Install window regulator handle, if equipped, and door latch remote control handle.
- (4) Install armrest and overlay.
- (5) Install assist handle, if equipped.
 - (a) Position assist handle and install attaching screws.

- (b) Install woodgrain inserts.
- (6) Install power window bezel, if equipped.

Replacement

- (1) Remove door trim panel.
- (2) If equipped with manual window regulator, assist handle, or ash receiver:
 - (a) Cut opening(s) in replacement trim panel, following outline(s) provided on backside of trim panel, with sharp knife.
- (3) If equipped with power windows, it will be necessary to cut opening for switch in replacement trim panel following outline provided on backside of trim panel with sharp knife.
- (4) Transfer door trim panel attaching clips to replacement panel.
- (5) Install door trim panel.

SEALING SYSTEM

Water Shield

The water shield is attached to the door inner panel with adhesive. To remove water shield, use a putty knife between shield and door inner panel to break adhesive bond.

When installing water shield, be sure the tab on the lower portion is tucked inside the door panel slit at the access opening and that the shield is bonded securely to the door inner panel.

Rubber Sealer

The door rubber sealer is made of molded latex foam with a smooth rubber skin on the outside.

The rubber sealer is attached to the door body opening.

Maintenance of Rubber Sealers

Cold weather may cause the rubber sealer to harden and lose resiliency. This may cause the door to loosen in its opening, resulting in noise. When servicing, use a dampened cloth to clean rubber sealer. Clean dirt from all points where the rubber sealer contacts the body. Apply AMC Silicone Lubricant, or equivalent, to sealer.

CAUTION: Do not use graphite, brake fluid or wax on rubber sealer.

Replacement

Replacement rubber sealers are coated with powder to prevent stickiness in storage. Before installation, remove all powder with a cloth dampened with 3M General Purpose Adhesive Cleaner, or equivalent.

- (1) Carefully remove rubber sealer from door opening.

- (2) Remove dust and dirt from rubber sealer, door and body.

- (3) Install upper front corner of sealer to door opening first.

- (4) Complete installation of rubber sealer to remainder of door opening.

WINDOW SYSTEM

Door Glass

Removal

- (1) Remove door trim panel and water shield.
- (2) Remove glass down stop bracket.
- (3) Remove division channel lower attaching bracket.
- (4) Lower door glass to obtain access to retainer.
- (5) Remove retainer, disengage pin from slot in channel and lower glass to bottom of door (fig. 3J-5).
- (6) Remove inner and outer belt weatherstrips.
- (7) Remove upper glass slide channel.
- (8) Remove stationary vent assembly attaching screws (fig. 3J-5).
- (9) Tilt top of vent assembly forward approximately one inch.
- (10) Push lower end of division channel toward rear of door to release glass.
- (11) Move glass toward rear of door to release glass from front glass slide channel.
- (12) Rotate glass 90° and guide glass between inner and outer door panels.

Installation

- (1) Position door glass in lower section of door so bottom channel has recessed portion toward outer door panel.
- (2) Position door glass in front glass slide channel and push division channel over glass.
- (3) Slide glass up and crank regulator arm down until pin on regulator arm can be inserted in slot of bottom channel.
- (4) Install retainer.
- (5) Position stationary vent assembly and install attaching screws.
- (6) Install upper glass slide channel.
- (7) Install inner and outer belt weatherstrip.
- (8) Install division channel lower attaching bracket.
- (9) Install glass down stop bracket.
- (10) Check operation of glass.
- (11) Install water shield and door trim panel.

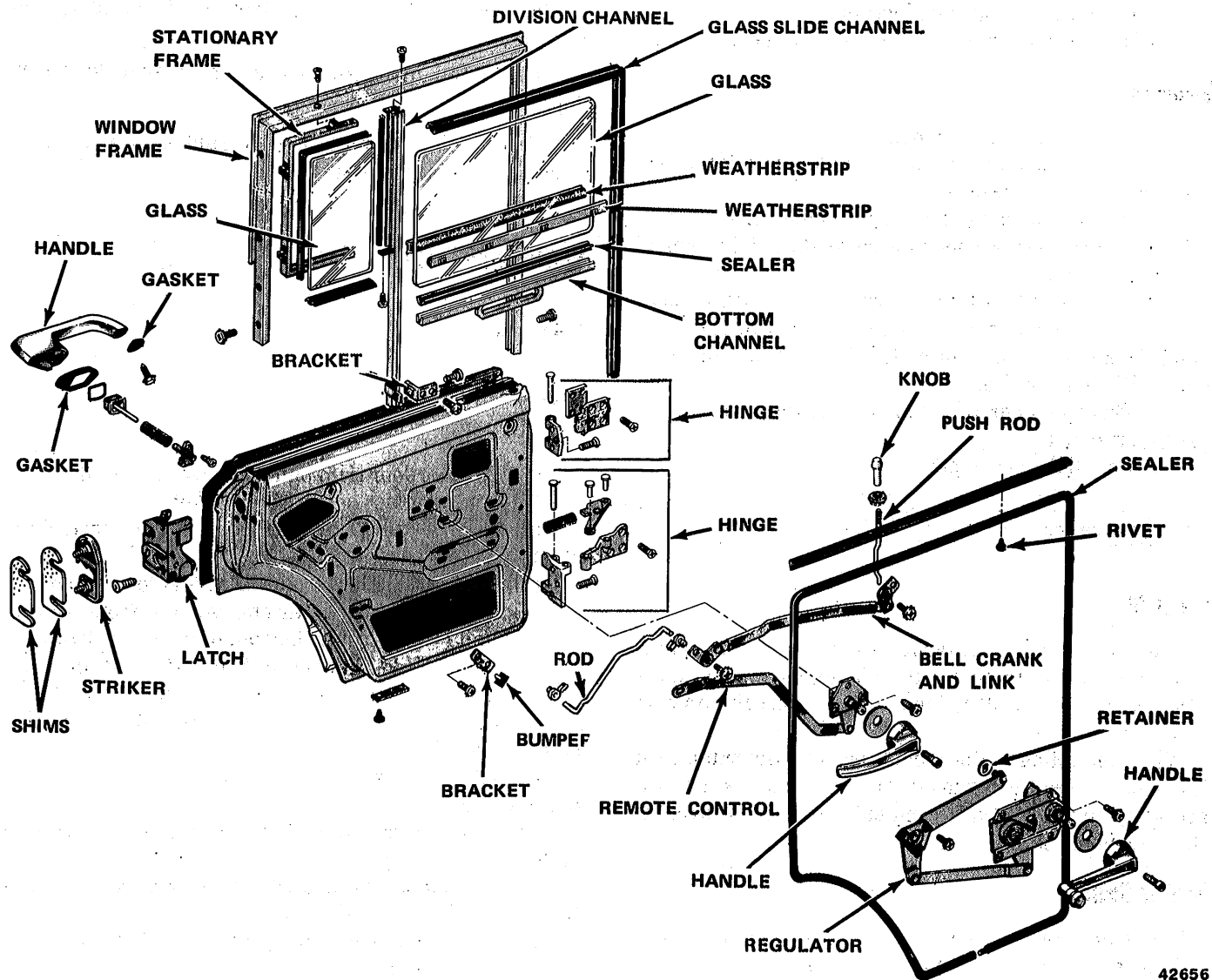

42656

Fig. 3J-5 Rear Door—Cherokee-Wagoneer Models

Vent Window

Removal

- (1) Remove door glass.
- (2) Apply soap solution under vent weatherstrip and along inner and outer door panels.
- (3) Slide vent assembly forward to center of door glass opening.
- (4) Push vent assembly down through opening between inner and outer door panels to disengage assembly from upper door frame.
- (5) Lower top of vent assembly down to clear upper door frame.
- (6) Pull vent assembly straight up until weather-seals are clear of door panel and vent assembly can be rotated.

(7) Rotate assembly to position lower attaching bracket on channel and pull assembly up and out between panels.

Installation

- (1) Install assembly between panels.
- (2) Engage vent assembly in upper door frame and slide vent into position.
- (3) Install attaching hardware.
- (4) Install door glass.

Window Regulator

Removal

- (1) Remove door trim panel and water shield.
- (2) Apply masking tape to each side of glass over top of window frame to hold glass during regulator removal.

(3) Remove regulator arm-to-glass bottom channel retainer.

(4) Push regulator pin out of glass bottom channel.

(5) Remove regulator attaching screws and remove regulator.

Installation

(1) Position regulator on inner door panel and secure with attaching screws.

(2) Install regulator pin in bottom channel and install retainer.

(3) Remove tape from glass.

(4) Install water shield and door trim panel.

LOCK SYSTEM

Outside Handle

Removal

(1) Remove door trim panel and water shield.

(2) Raise window to fully closed position.

(3) Through opening in inner door panel, remove handle attaching screws and remove handle and gaskets.

Installation

(1) Position gaskets and handle on door and secure with attaching screws.

(2) Install water shield and door trim panel.

Locking Rod

Removal

(1) Remove door trim panel and water shield.

(2) Remove door lock push knob.

(3) Loosen latch mounting screws using Torx Bit Tool J-25359-C and disengage locking rod by rotating metal clip on rod and pulling rod out of plastic bushing.

Installation

(1) Engage locking rod to latch and tighten latch mounting screws using Torx Bit Tool J-25359-C.

(2) Install door lock push knob.

(3) Install water shield and door trim panel.

Remote Control and Lock Lever Rod

Removal

(1) Remove door trim panel and water shield.

(2) Remove door lock push knob.

(3) Remove screws attaching lock control arm to inner door panel.

(4) Remove lock lever rod.

(5) Remove door latch attaching screws using Torx Bit Tool J-25359-C.

(6) Disconnect remote control arm and turn latch 90°.

(7) Remove lock lever rod and bellcrank (fig. 3J-5).

Installation

(1) Position latch in door and install lock lever rod and bellcrank.

(2) Connect remote control arm to latch and turn latch 90°. Secure latch to door panel with attaching screws using Torx Bit Tool J-25359-C.

(3) Install lock lever rod.

(4) Position lock control arm on inner door panel and install attaching screws.

(5) Install door lock push knob.

(6) Install water shield and trim panel.

HINGE SYSTEM

Replacement—One Hinge

(1) Mark outline of existing hinge on body pillar and door with wax pencil for reference.

(2) Position door in holding fixture.

(3) Remove hinge screws using Torx Bit Tool J-25359-C and remove hinge. Retain shims.

(4) Clean replacement hinge in suitable solvent and blow dry with compressed air.

CAUTION: Do not immerse hinge in solvent.

(5) Color-coat hinge to match body.

(6) Lubricate hinge with 3M 4-Way Spray lubricant, or equivalent.

(7) Position hinge on door with original shims, being careful to align with wax pencil marks, and install screws using Torx Bit Tool J-25359-C. Tighten screws to 12 to 18 foot-pounds (16 to 24 N•m) torque.

(8) Remove door holding fixture.

(9) Check door alignment. Adjust if necessary. Refer to Door Adjustments.

Door Removal

(1) Remove door trim panel and water shield.

(2) Raise door glass to closed position.

(3) Disconnect electrical harnesses inside door and remove harnesses.

(4) Position door in holding fixture and using wax pencil scribe outline of hinges on door for reference.

(5) Remove all hinge-to-door attaching screws using Torx Bit Tool J-25359-C.

(6) Remove door from vehicle.

Installation

- (1) Position door in body opening, being careful to align with wax pencil marks, and install screws using Torx Bit Tool J-25359-C. Tighten screws to 12 to 18 foot-pounds (16 to 24 N•m) torque.
- (2) Remove holding fixture.
- (3) Position electrical harnesses inside door.
- (4) Connect electrical harnesses.
- (5) Check door adjustment. Adjust if necessary. Refer to door adjustments.
- (6) Install water shield and trim panel.

Door Adjustments

The doors are adjusted at the hinge mounting points on the body or door.

Floating plates are located in the body pillars to permit adjustment up, down, in or out. To adjust forward or back, add or remove shims between the hinge and hinge pillar.

Prior to any door adjustment or alignment, the adjustable striker must be removed to allow the door to close freely in proper alignment without striker interference.

The door lock striker is adjustable up, down, in or out and can be shimmed forward or back to hold the door in the properly aligned position.

The door latch striker should be set so that the latch enters the striker without binding, yet provides secure retention for the lock and prevents up and down or in and out movement of the door.

The striker also should be adjusted in or out to allow the door latch to be fully engaged. The door should be flush with the adjacent body panels.

NOTE: *It is possible to set the striker in so far that the door is closed tight but only the safety catch is engaged. This will prevent locking the door with the pushbutton lock rod.*

ELECTRICALLY OPERATED WINDOWS

	Page		Page
Circuit Tests	3J-16		
Control Switch	3J-17	Motor	3J-19
Front Door Regulator and Motor	3J-18	Motor Test	3J-19
General	3J-16	Rear Door Regulator and Motor	3J-18
		Switch Voltage Tests	3J-18

GENERAL

The window regulator motors (fig. 3J-6) are of a two-wire design, using polarity of the circuit to change motor rotation.

An individual control switch is provided for each side window and is mounted in the door trim panel. A complete set of control switches on the driver's door enables remote control operation of all side windows. The ignition switch must be in the On position to operate the windows.

CIRCUIT TESTS

A 30-amp circuit breaker, located in the fuse panel, is mounted at the far left side above the parking brake release handle (fig. 3J-7).

The circuit breaker (yellow and red wires) supplies power to the electric side windows when the ignition switch is in the On position. The black wires at the master control switch are the ground wires for the electric window circuits. They join in the harness and ground to the instrument panel harness ground circuit at lower left corner of the instrument panel.

NOTE: *The control switches, motors and wiring harness can be checked using a 12-volt test lamp.*

- (1) Remove escutcheon and housing.
- (2) Separate halves of terminal plate by releasing barbed retainer hooks to expose wire terminal ends.
- (3) Turn ignition switch to On position.
- (4) Connect one lead of test lamp to black wire and contact other lead to red terminal. Repeat this test procedure with second black wire in master switch.
 - (a) If lamp does not light, remove test lamp lead that was on black wire terminal and connect to chassis ground.
 - (b) If lamp lights at this point, an opening exists between master switch and ground.
 - (c) If lamp still does not light, check for defective circuit breaker or opening in red wire from circuit breaker to master switch.

Circuit Breaker Test

- (1) Disconnect yellow wire from circuit breaker and connect test lamp between yellow wire and chassis ground.

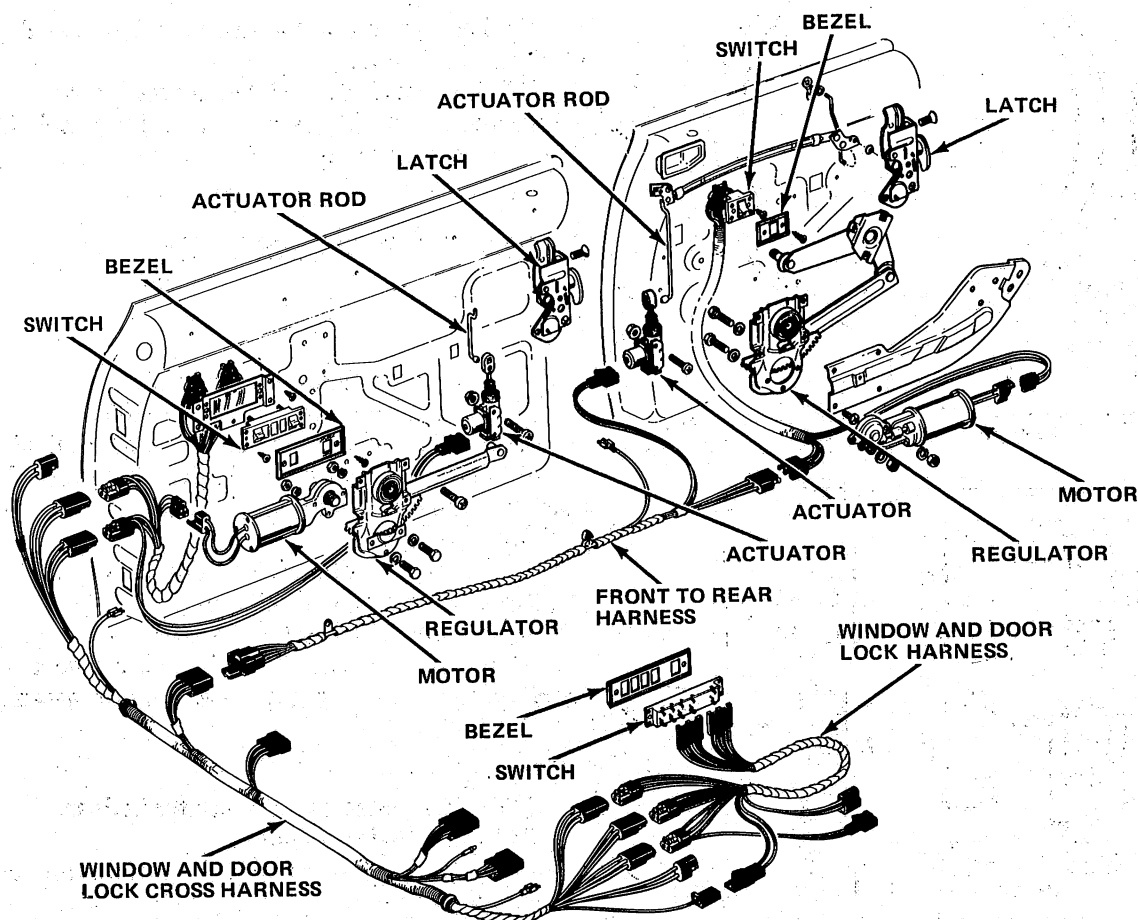

81007

Fig. 3J-6 Electrically Operated Door Windows and Door Locks

(2) Turn ignition switch to On position. If lamp does not light, yellow wire has an open circuit or ignition switch is defective.

(3) Reconnect yellow wire to circuit breaker.

(4) Disconnect red wire from circuit breaker and connect test lamp to circuit breaker terminal and chassis ground. If lamp lights, circuit breaker is good. If lamp does not light, circuit breaker is defective.

Control Switch and Motor Test

(1) Connect test lamp between terminals of yellow and orange wire.

(2) Operate control switch up and down for respective window. If lamp lights in Up and Down position, test indicates that yellow and orange wires of wire harness to that window and back again to master switch are not defective. It also indicates that individual door switch on master control is not defective.

(3) Disconnect white and green motor leads at terminal plate and connect these leads to green and white leads respectively.

(4) Operate master switch. If window goes up and down, motor is not defective but switch is defective. If motor does not operate, remove door trim panel and

check connections and leads to motor. If motor operates, switch is defective.

NOTE: It may be possible that switch and motor both are defective.

CONTROL SWITCH

Removal

CAUTION: Be sure ignition switch is in Off position.

- (1) Disconnect battery negative cable.
- (2) Remove retaining screws and escutcheon.
- (3) Remove switch housing screws. Pull switch out to expose wires.
- (4) Disconnect terminal plate from switch.
- (5) Depress retainer clips through holes in switch housing and remove switch.

Installation

- (1) Hold retainer clips in position on switch and slide switch into housing. Press retainer clips until they click into position.

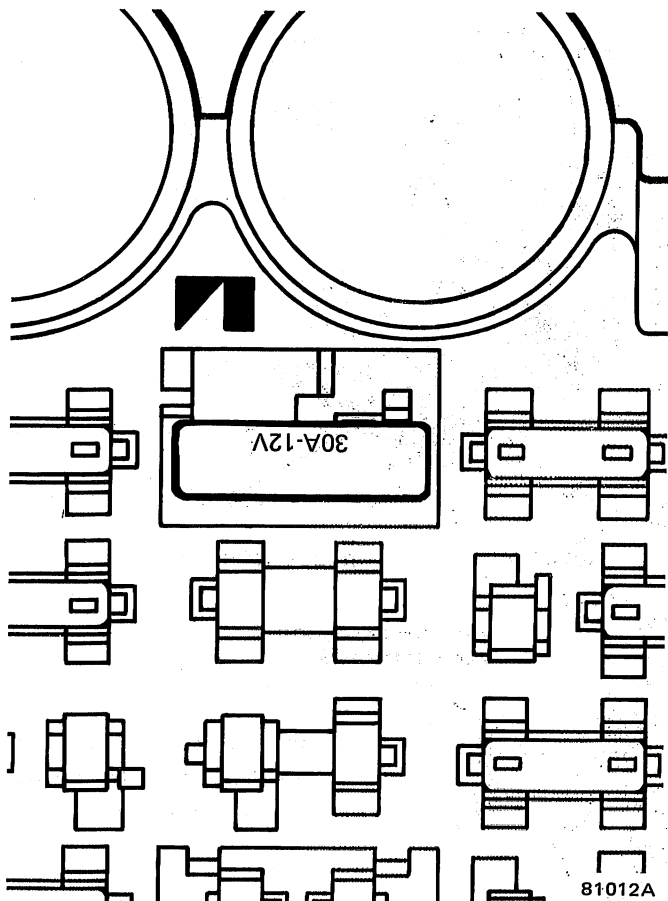

Fig. 3J-7 Circuit Breaker Location

- (2) Install terminal plate to switch and install housing in door.
- (3) Install escutcheon and retaining screws.
- (4) Connect battery negative cable.

FRONT DOOR REGULATOR AND MOTOR

Removal

- (1) Raise window half-way up.
- (2) Disconnect battery negative cable.
- (3) Remove door trim panel and water shield.
- (4) Insert drift into hole in door inner panel or use masking tape to hold glass assembly in half-way position.
- (5) Remove regulator arm retainer clip and remove arm from bottom window channel.
- (6) Disconnect wires from motor.
- (7) Remove nuts and bolts from inner door panel to regulator and remove regulator and motor assembly.

Installation

- (1) Install replacement regulator in door.
- (2) Connect wires to motor.
- (3) Connect regulator arm to glass bottom channel and install clip.

- (4) Position regulator in inner door panel and install nuts and bolts.
- (5) Remove tape or drift holding window.
- (6) Install water shield and trim panel. Connect negative battery cable.

REAR DOOR REGULATOR AND MOTOR

Removal

- (1) Raise the window half way up.
- (2) Disconnect battery negative cable.
- (3) Remove door trim panel and water shield.
- (4) Insert drift into hole in door inner panel or use masking tape to hold glass assembly in half-way position.
- (5) Remove regulator arm retainer clip and remove arm from bottom window channel.
- (6) Disconnect wires from motor.
- (7) Remove nuts and bolts from inner door panel to regulator and remove regulator and motor assembly.

Installation

- (1) Install replacement regulator in door.
- (2) Connect wires to motor.
- (3) Connect regulator arm to glass bottom channel and install clip.
- (4) Position regulator in inner door panel and install nuts and bolts.
- (5) Remove tape or drift holding window.
- (6) Install water shield and trim panel. Connect negative battery cable.

SWITCH VOLTAGE TESTS

The following wiring test sequence determines whether or not voltage is continuous through the harness to switch.

Leave ignition switch in the On position. After removing the switch from the trim panel for testing purposes, carefully separate the multiple terminal block on the wiring harness from the switch body. Connect one lead of the test lamp lead to the red wire terminal and the other to ground. If the test lamp lights, the wiring circuit between the battery and switch is functional, proceed to check the continuity in the ground circuit (black wire). If the lamp does not light, check 30-amp main fuse (circuit breaker) or for a broken wire.

Switch Up Test

- (1) Connect jumper to red lead and other end of jumper lead to Up terminal as shown in figure 3J-8. Connect another jumper to ground terminal of switch. Connect other end of second jumper wire to Down terminal of switch.

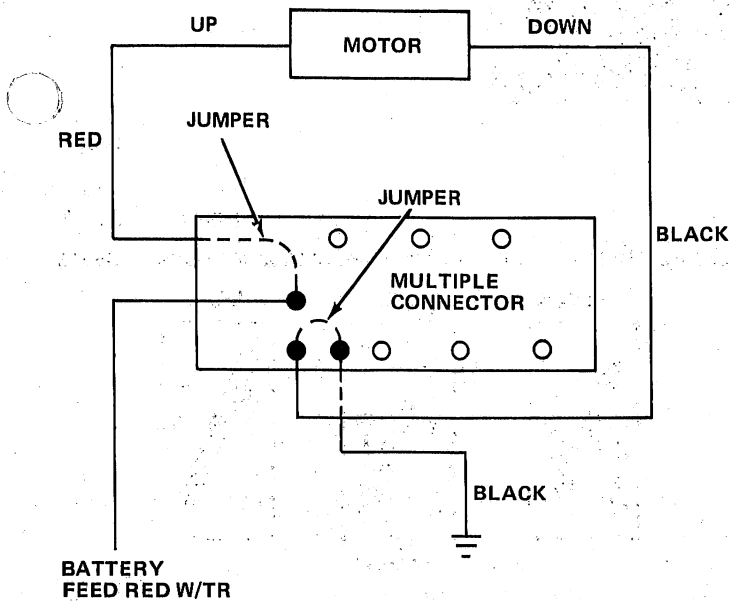

81012B

Fig. 3J-8 Motor Switch UP Test

(2) If motor runs, test verifies that voltage is available to motor. Switch must now be tested to make sure that voltage is passing through satisfactorily. Install switch body back on multiple connector and actuate switch. If motor fails to run, replace switch body. Each switch is tested in same manner.

(3) If motor does not run after installing new switch, perform Motor Test.

Switch Down Test

(1) Connect jumper lead to red terminal lead and other end of jumper to Down terminal as shown in figure 3J-9. Connect another jumper to ground terminal of switch and other end of jumper wire to Up terminal of switch.

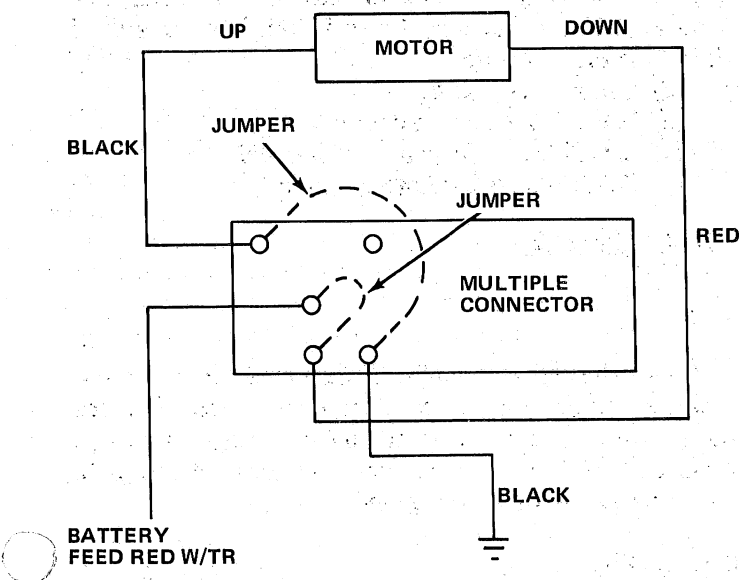

81012C

Fig. 3J-9 Motor Switch DOWN Test

(2) If motor runs, test verifies that voltage is available to motor. Install switch body back on multiple connector and actuate switch. If motor fails to run, replace switch body. Each switch is tested in same manner.

(3) If motor does not run, perform Window Motor Test.

MOTOR TEST

(1) Connect positive (+) lead (from a test battery) to either terminal.

(2) Connect negative (-) lead (from test battery) to remaining motor terminal.

(3) Motor should now rotate in one direction to either move window up or down.

(a) If window happens to already be in full Up position and motor is connected so as to rotate in Up direction no movement will be observed.

(b) Likewise, motor connected to Down direction rotation, no movement will be observed if window is already in full down position.

(4) Reverse battery leads opposite to steps (1) and (2). Window should now move. If window does not move, remove motor for bench test as described below. vehicle for bench test.

(5) If window moved completely up or down, motor should be reversed one more time (reverse leads to complete a full window travel inspection).

MOTOR

Removal

- (1) Disconnect battery negative cable.
- (2) Remove door trim panel and windshield.
- (3) Remove motor attaching bolts and nuts.

WARNING: The regulator assembly is spring loaded. The door glass must be supported in the Up position with the regulator arm connected to the lower glass slide channel. This prevents the regulator spring from unloading.

(4) Disconnect lead wires from motor and remove motor.

Installation

- (1) Connect lead wires to motor.
- (2) Install motor in door panel and remove glass support.
- (3) Install door trim panel and watershield.
- (4) Connect battery negative cable.

POWER DOOR LOCKS

	Page
Actuator Motor	3J-20
Circuitry	3J-20

	Page
General Switch	3J-20
	3J-20

GENERAL

Door lock actuators are controlled by two rocker switches. To lock doors, push down on either switch. To unlock doors from inside the vehicle push upward on either switch.

The power door locks do not lock or unlock the doors from outside the vehicle. Insert the key into the lock cylinder to lock or unlock each individual door.

CIRCUITRY

The power door lock operates with battery power and, therefore, is independent of the ignition switch.

A 30-amp circuit breaker mounted in the fuse block protects the circuit. Refer to wiring diagrams in the back of this manual for complete circuits. The front door harness runs from door to door and is secured to the dash panel with harness retainers.

On four-door models, the right and left rear door harnesses are connected to the front door harness at the top of the side-cowl panels. They are routed along the side sill to the B-pillar, then through the bottom of the B-pillar to the rear doors.

If the vehicle is equipped with power windows, the door lock wires become part of the combined wire harnesses. The wire routing still follows the above description.

Circuit Breaker Test

Disconnect harness connector from fuse panel. Test fuse panel connection with test lamp. If lamp lights, battery voltage is present. If no battery voltage is present, remove circuit breaker and test with ohmmeter. If circuit breaker is OK then check for battery voltage at circuit breaker connection on fuse panel. If no battery voltage at fuse panel check for failure of fuse links in engine compartment.

Switch Test

Test door switches for continuity with a self-powered Test Lamp J-21008, or ohmmeter. Continuity should exist between terminals at various switch positions as shown in figure 3J-10.

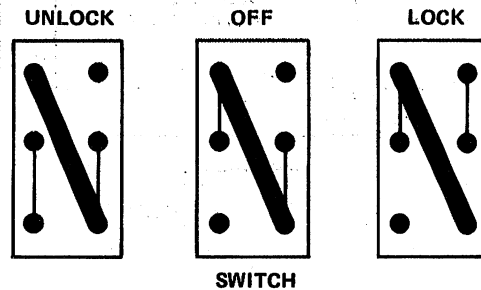

81012D

Fig. 3J-10 Continuity Test for Power Door Lock Switch

SWITCH

Removal

- (1) Disconnect battery negative cable.
- (2) Remove door trim panel and watershield.
- (3) Remove switch housing from inner door panel.
- (4) Disconnect wiring and remove switch. Connector is retained to switch with clips, pry clips up to disconnect.
- (5) Depress retainer clips through holes in switch housing and remove switch.

Installation

- (1) Hold retainer clips in position on switch and slide switch into housing. Press in retainer clips until they snap into position.
- (2) Connect wiring to switch.
- (3) Install housing into door panel.
- (4) Install watershield and trim panel.
- (5) Connect negative battery cable.

ACTUATOR MOTOR

Test

To test the actuator motor, attach an ammeter to the motor terminals and operate the door switch. Replace the actuator motor if current draw exceeds 8 amps at room temperature or if the actuator does not complete its travel in less than one second.

Replacement

- (1) Disconnect battery negative cable.
- (2) Remove door trim panel and watershield.

(3) Remove actuator motor by drilling out rivets attaching motor to door panel with a 1/4-inch drill bit.

(4) Disconnect actuator rod from bellcrank.

(5) Disconnect wires from actuator motor and remove actuator motor.

(6) Connect wires to actuator motor and connect rod to actuator.

(7) Install actuator in door panel using two 1/4-20 x 1/2-inch screws and locknuts or rivets and connect bellcrank rod to bellcrank.

(8) Install watershield and door trim panel.

(9) Connect battery negative cable.

Tools

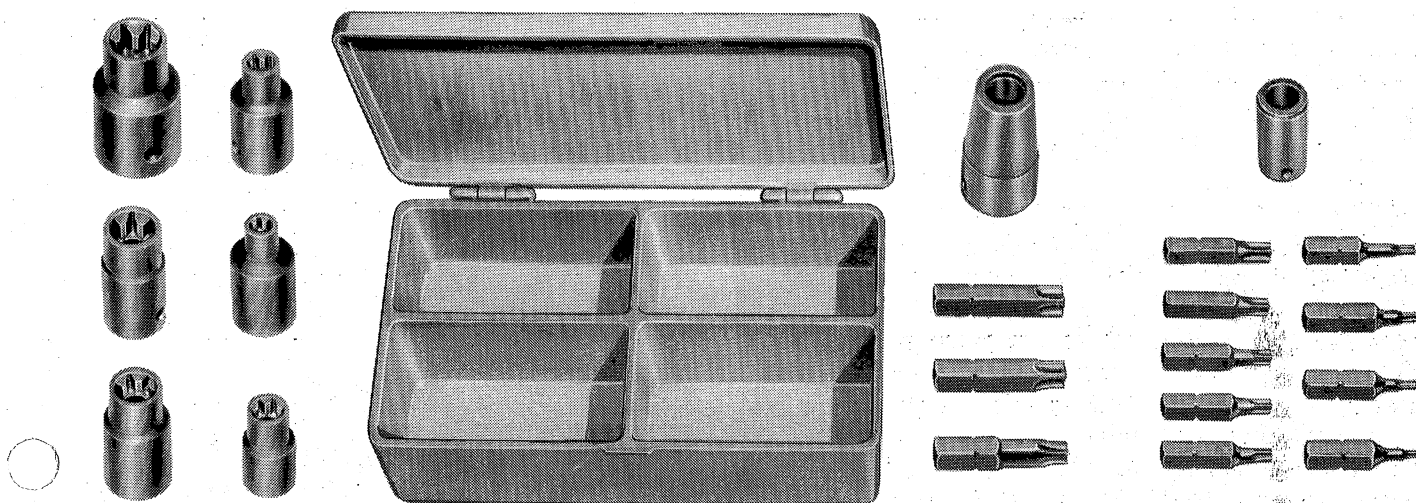

J-25359-C
TORX BIT AND
SOCKET SET



J-2631-01
TRIM PAD DEPRESSOR



J-21104-01
WEATHERSTRIP
REMOVER

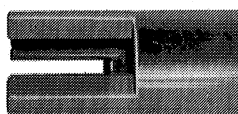

J-22977
TUMBLER FILING
FIXTURE

